

Chrysler Starter Plugs

More and more OE manufacturers seem to be moving toward plug-in connections for the S-terminal of starters. This makes sense—it gives a positive locking connection and creates a seal that helps to keep out moisture. However, for the aftermarket this makes starters less interchangeable and more fragile.

In recent years, Chrysler has gone toward using plug connectors with nearly their whole line of starters, which are produced by Nippondenso and Bosch. These now come with a “Chrysler Oval Plug” and much of this transition was handled by Chrysler as a running change.

Chrysler OE#: 4686045

Nippondenso Plug
1993-1998 Chrysler Vehicles

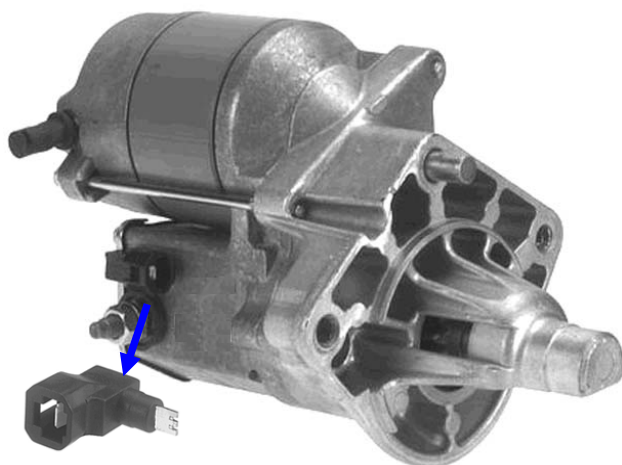

Chrysler OE#: 4686045AB (or AC)

Chrysler Oval Plug
1998-2001 Chrysler Vehicles

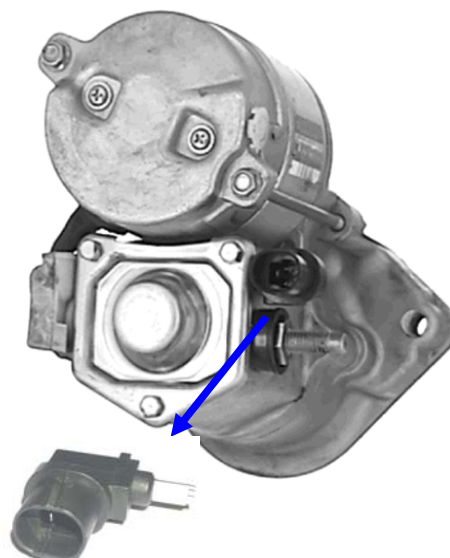

Since this was a running change, it is essential to confirm the type of plug on the customer’s original starter. One way to check which starter is correct is to cross-reference the OE numbers...but be careful! In many cases the Chrysler OE numbers are the same, except for the letter suffix.

This list contains additional part numbers that are subject to this running change:

AutoZone #	Plug Type	Applications, abbreviated (model year cut-off may NOT be absolute)
17012	Nippondenso	1993-1999 Caravan, Voyager, Town & Country w/ 3.3L or 3.8L
17725	Chrysler oval	1998-2000 Caravan, Voyager, Town & Country w/ 3.3L or 3.8L
17759	Chrysler oval	2001 Caravan, Voyager, Town & Country w/ 3.3L or 3.8L
17203	Nippondenso	1995-1997 Neon, Stratus, Breeze w/ 2.0L
17618	Chrysler oval	1998-2000 Neon, Stratus, Breeze, Cirrus w/ 2.0L
17253	Nippondenso	1996-1998 Wrangler, Cherokee, Dakota w/ 2.5L
17679	Chrysler oval	1999-2000 Wrangler, Cherokee, Dakota w/ 2.5L
17274	Threaded post	1996-1998 B Series Van, D/W Series Pick-up, Dakota (all w/ gasoline engine)
17677	Chrysler oval	1998-2001 B Series Van, D/W Series Pick-up, Dakota (all w/ gasoline engine)